

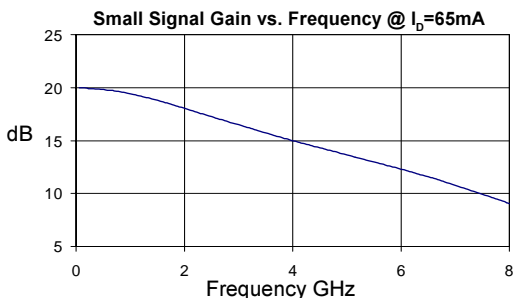

Product Description

Sirenza Microdevices' SNA-586 is a high performance Gallium Arsenide Heterojunction Bipolar Transistor MMIC Amplifier. A Darlington configuration is utilized for broadband performance up to 5 GHz. The heterojunction increases breakdown voltage and minimizes leakage current between junctions. Cancellation of emitter junction non-linearities results in higher suppression of intermodulation products. Typical IP3 at 850 MHz with 65mA is 32.5 dBm.

These unconditionally stable amplifiers provide 18 dB of gain and 18.4 dBm of 1dB compressed power and require only a single positive voltage supply. Only 2 DC-blocking capacitors, a bias resistor and an optional inductor are needed for operation.



SNA-586

DC-5 GHz, Cascadable GaAs HBT MMIC Amplifier

NGA-586 Recommended for New Designs



Product Features

- High Output IP3: 32.5 dBm @ 850 MHz
- Cascadable 50 Ohm Gain Block
- Patented GaAs HBT Technology
- Operates From Single Supply

Applications

- Cellular, PCS, CDPD, Wireless Data, SONET

Symbol	Parameter	Frequency	Units	Min.	Typ.	Max.
P_{1dB}	Output Power at 1dB Compression	850 MHz	dBm		17.6	
		1950 MHz	dBm		18.4	
		2400 MHz	dBm		18.4	
OIP_3	Output Third Order Intercept Point	850 MHz	dBm		32.5	
		1950 MHz	dBm		31.6	
		2400 MHz	dBm		31.6	
S_{21}	Small Signal Gain	850 MHz	dB	17.6	19.6	21.6
		1950 MHz	dB		18.1	
		2400 MHz	dB		17.4	
Bandwidth	(Determined by S_{11} , S_{22} Values)		MHz		5000	
$VSWR_{IN}$	Input VSWR	DC-5000 MHz	-		1.4:1	
$VSWR_{OUT}$	Output VSWR	DC-5000 MHz	-		1.4:1	
S_{12}	Reverse Isolation	850 MHz	dB		22.3	
		1950 MHz	dB		21.6	
		2400 MHz	dB		21.3	
NF	Noise Figure	1950 MHz	dB		4.0	
V_D	Device Operating Voltage		V	4.4	4.9	5.4
$R_{TH, j-l}$	Thermal Resistance (junction - lead)		$^{\circ}\text{C/W}$		254	

Test Conditions:

$$V_S = 8\text{ V}$$

$$R_{BIAS} = 47\text{ Ohms}$$

$$I_D = 65\text{ mA Typ.}$$

$$T_L = 25^{\circ}\text{C}$$

$$OIP_3\text{ Tone Spacing} = 1\text{ MHz, } P_{out}\text{ per tone} = 0\text{ dBm}$$

$$Z_S = Z_L = 50\text{ Ohms}$$

The information provided herein is believed to be reliable at press time. Sirenza Microdevices assumes no responsibility for inaccuracies or omissions. Sirenza Microdevices assumes no responsibility for the use of this information, and all such information shall be entirely at the user's own risk. Prices and specifications are subject to change without notice. No patent rights or licenses to any of the circuits described herein are implied or granted to any third party. Sirenza Microdevices does not authorize or warrant any Sirenza Microdevices product for use in life-support devices and/or systems. Copyright 2001 Sirenza Microdevices, Inc.. All worldwide rights reserved.

Absolute Maximum Ratings

Operation of this device above any one of these parameters may cause permanent damage.

Bias Conditions should also satisfy the following expression:

$$I_D V_D (\text{max}) < (T_J - T_{OP})/R_{th, j-l}$$

Parameter	Value	Unit
Supply Current	110	mA
Operating Temperature	-40 to +85	C
Maximum Input Power	16	dBm
Storage Temperature Range	-40 to +150	C
Operating Junction Temperature	+175	C

Parameter	Typical		Test Condition ($I_D = 65 \text{ mA}$, unless otherwise noted)
	25°C	Unit	
500 MHz			
Gain	19.8	dB	$Z_s = 50 \text{ Ohms}$ Tone spacing = 1 MHz, Pout per tone = 0 dBm
Noise Figure	3.9	dB	
Output IP3	31.8	dBm	
Output P1dB	17.4	dBm	
Input Return Loss	14.1	dB	
Isolation	22.5	dB	
850 MHz			
Gain	19.6	dB	$Z_s = 50 \text{ Ohms}$ Tone spacing = 1 MHz, Pout per tone = 0 dBm
Noise Figure	4.0	dB	
Output IP3	32.5	dBm	
Output P1dB	17.6	dBm	
Input Return Loss	15.6	dB	
Isolation	22.3	dB	
1950 MHz			
Gain	18.1	dB	$Z_s = 50 \text{ Ohms}$ Tone spacing = 1 MHz, Pout per tone = 0 dBm
Noise Figure	4.0	dB	
Output IP3	31.6	dBm	
Output P1dB	18.4	dBm	
Input Return Loss	16.6	dB	
Isolation	21.6	dB	
2400 MHz			
Gain	17.4	dB	Tone spacing = 1 MHz, Pout per tone = 0 dBm
Output IP3	31.6	dBm	
Output P1dB	18.4	dBm	
Input Return Loss	16.8	dB	
Isolation	21.3	dB	

***NOTE:** While the SNA-586 can be operated at different bias currents, 65 mA is the recommended bias for lower junction temperature and longer life. This reflects typical operating conditions which we have found to be an optimal balance between high IP3 and MTTF. In general, MTTF is improved to more than 100,000 hours when biasing at 65 mA and operating up to 85°C ambient temperature.

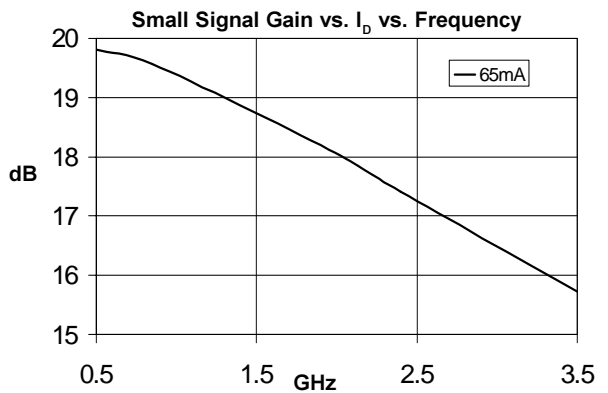
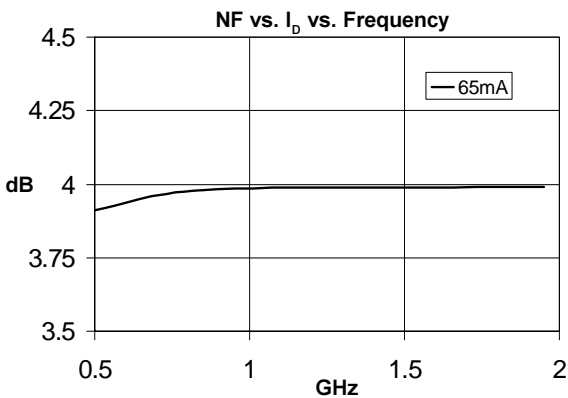
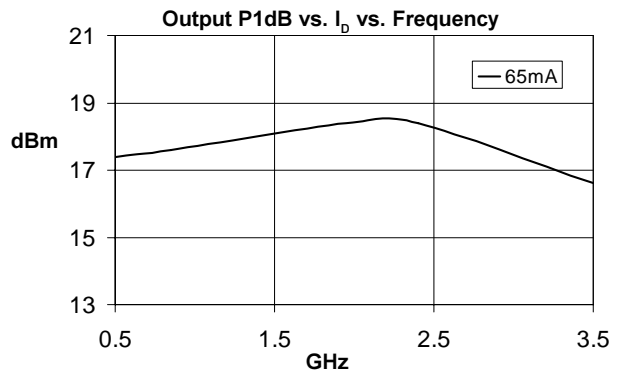
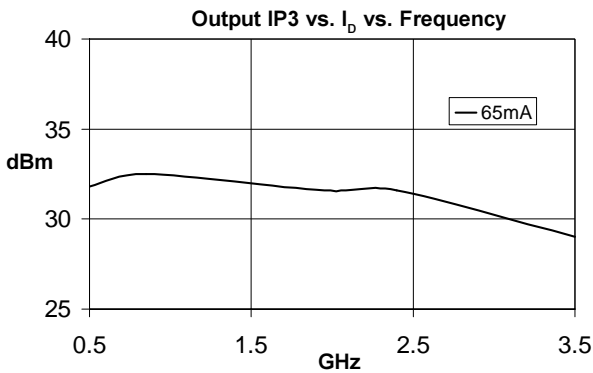
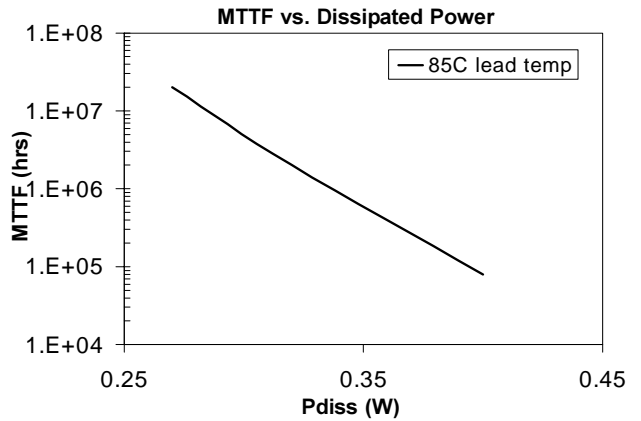
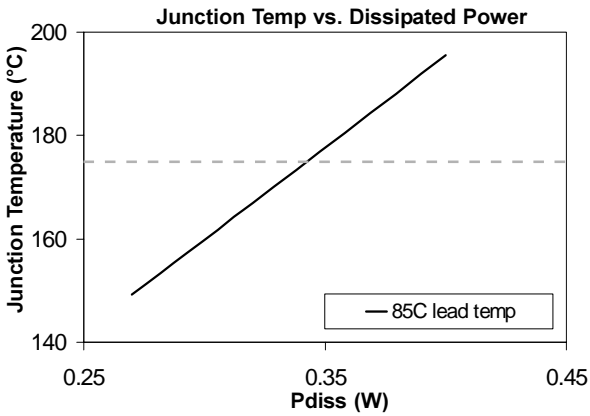

Pin #	Function	Description
1	RF IN	RF input pin. This pin requires the use of an external DC blocking capacitor chosen for the frequency of operation.
2	GND	Connection to ground. Use via holes for best performance to reduce lead inductance. Place vias as close to ground leads as possible.
3	RF OUT/Vcc	RF output and bias pin. Bias should be supplied to this pin through an external series resistor and RF choke inductor. Because DC biasing is present on this pin, a DC blocking capacitor should be used in most applications (see application schematic). The supply side of the bias network should be well bypassed.
4	GND	Same as Pin 2.

Application Schematic for Operation at 850 MHz

Recommended Bias Resistor Values				
Supply Voltage(Vs)	8V	9V	12V	15V
Rbias (Ohms) @ 65 mA	47	62	110	160

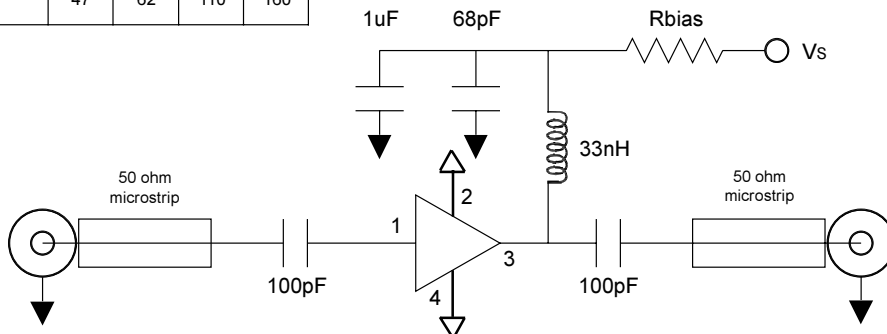

Application Schematic for Operation at 1950 MHz

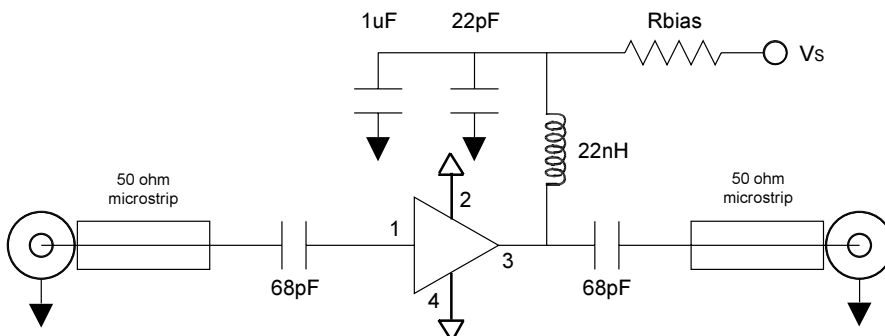

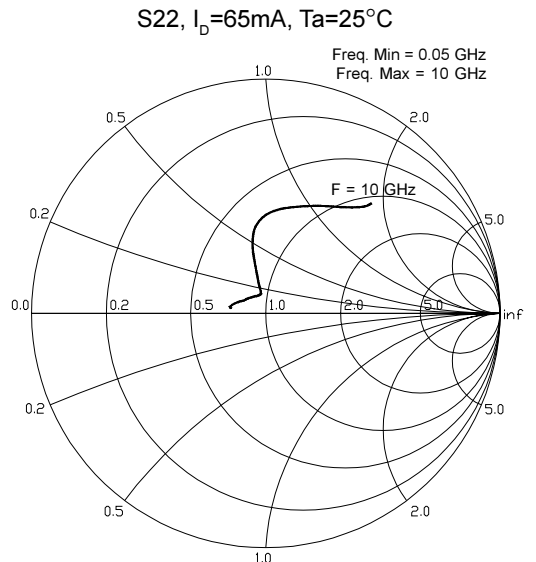
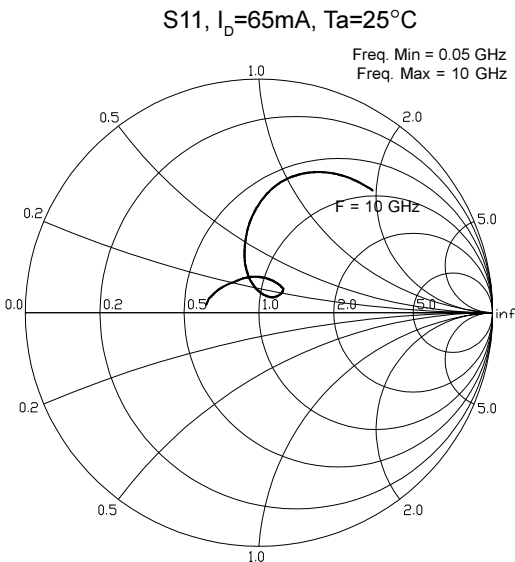
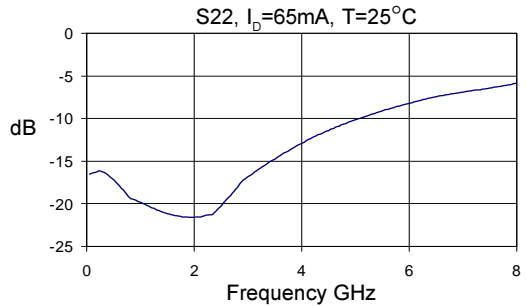
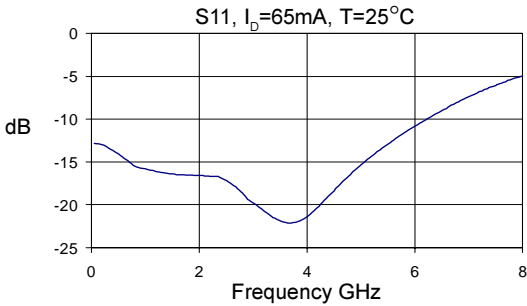
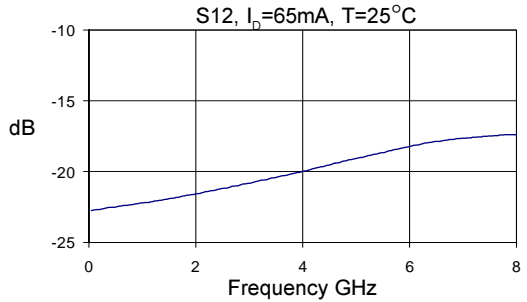
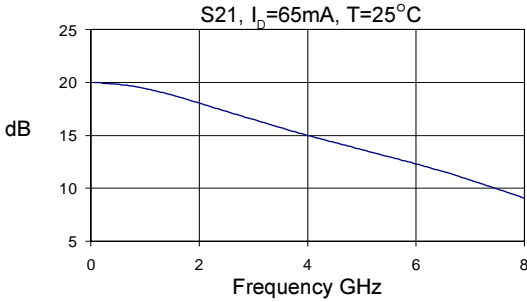

SNA-586 DC-5GHz Cascadable MMIC Amplifier

Part Number Ordering Information

Part Number	Reel Size	Devices/Reel
SNA-586	7"	1000



Caution ESD Sensitive:

Appropriate precautions in handling, packaging and testing devices must be observed.

Part Symbolization

The part will be symbolized with an "S5" designator on the top surface of the package.

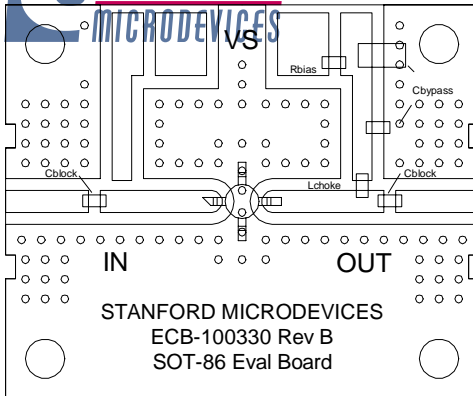

Evaluation Board Layout

PCB Pad Layout

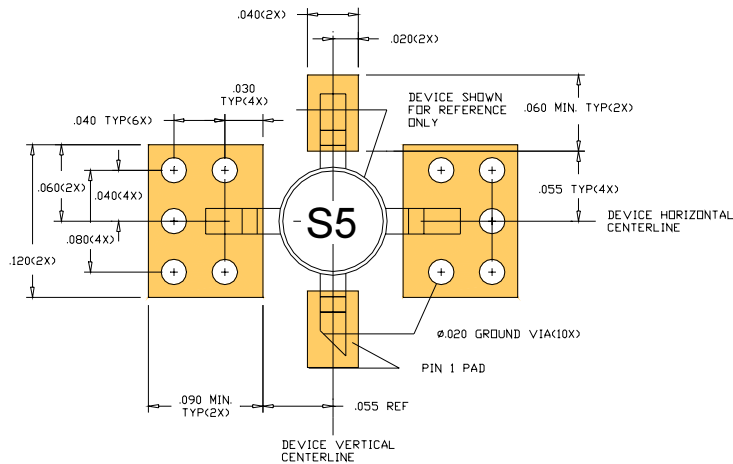

Package Dimensions

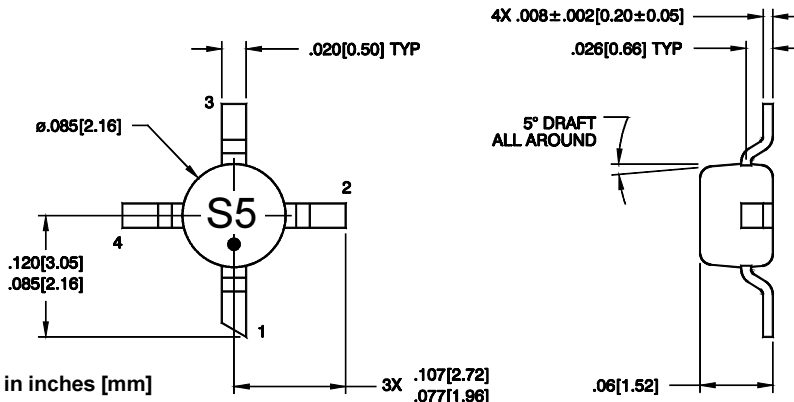

Dimensions are in inches [mm]